

Série 312 Black - Espiga

PVC (BPA.E)

DIFERENCIAIS DO PRODUTO:

Resiste à corrosão, apresenta boa mobilidade, baixo ruído, maciez, conforto e não marca o piso.

APLICAÇÃO:

Rodízios para cargas leves em móveis e acessórios de utilidades para o comércio, indústrias e centros logísticos.



COMPOSIÇÃO:

Roda: com duplo rolamento de esferas de precisão 6001ZZ, núcleo em polipropileno (preto) e banda de PVC (BP) (amarelo). Dureza 75 Shore A (-10°C a 50°C).

Garfo: em aço com acabamento epóxi (preto).

CAPACIDADE DE CARGA





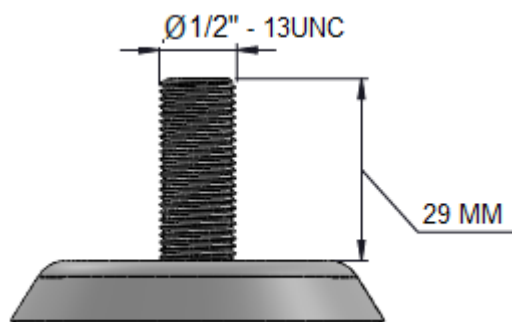

até 70 Kg



ESPIGA:

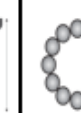

ESPECIFICAÇÕES:

								CÓDIGO DE REFERÊNCIA	
POLEGADAS	MILIMETROS	MILIMETROS	MILIMETROS	MILIMETROS	RODAGEM	EIXO (parafuso)	KILOGRAMAS	GIRATÓRIO	FREIO
3	32	40	65	102	√	10 mm	70	GLEB 312 BPA E	GLEBF 312 BPA E